



Whitepaper



Quantum Grid 1.0

First Generation

This revision of the 2017 white paper describes the patented 1st generation Quantum Grid for packet-based power transmission.

1. Abstract

The idea of routing energy packets in an electricity grid as proposed in this whitepaper, called Quantum Grid, has been invented and developed at GIP by Dr. Reifenhäuser and Dr. Ebbes and has already been patented in EU, USA and China [1], [2]. This power grid takes the internet as example by routing the electrical power in form of packets (quantized) through the grid.

Many other groups around the world deal with projects on new grids and new inverter technology. The concept of synchronous power transmission in form of packets instead of analogue power flows has already been published in 1996 by Toyoda et al. [3]. However, they did not introduce routing for these packets.

Three months after the publication of GIP in 2009, Prof. Abé, University of Tokyo, [4] [5] published a similar idea, called Digital Grid. Because of the non-disclosure period of the German patent process the work of R. Abé was totally independent to our work.

2. Motivation and challenges

If you get up in the morning, drink your coffee from the coffee machine and turn on the radio a whole invisible machinery in the background, is working to provide you at any time with the exact amount of energy you need. That's how it is and how it shall be in the future for everyone who pays for it. The fundamental principle of the traditional grid today is power on demand (Fig 1), realized by a seemingly infinite source of primary energy.

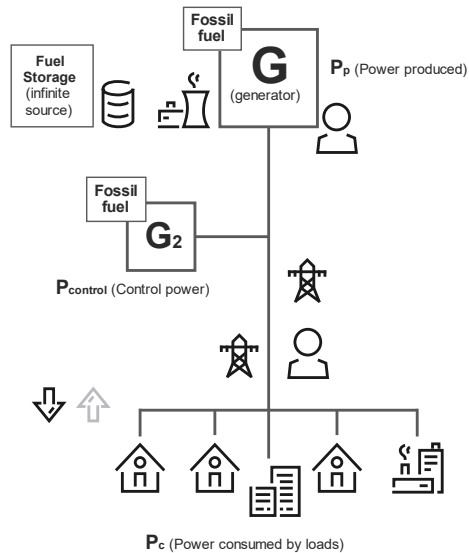

Today: Power on demand

- Central power supply
- Top down structure
- The condition

$$\sum P_p = \sum P_c$$

is fulfilled by deterministic sources

Fig. 1 Today's power on demand operation principle is only possible due to the usage of "unlimited" fossil fuel storage.

The transformation of mechanical rotation energy into electrical power and the electrical transmission based on the laws of Ohm and Kirchhoff give rise to the rigid coupling of sinks and sources. This rigid coupling realized by the electromagnetic field can be seen as a coupling by a torque of the generator and for instance an electrical drive. Hence, the classical grid is a rigid system sensitive to dynamics.

Since the amount of intermittent renewable generation increases in the grid, more dynamics are created and in consequence, a more flexible grid is needed. To overcome the rigid coupling, the fundamental operational principles of the electrical grid have to change.

So far, there are few approaches.

The most popular approach is the smart grid. In this concept, the load and generation are permanently controlled so that the power balance is fulfilled. This controlled exchange between energy consumption and energy production leads to an easier adaption of each other. The traditional grid remains as it is today. It is equipped with sensors at many points, which transmit all the information about the electrical energy in the grid to a central control center, which then processes the data and regulates the electrical power.

Within this approach, there are many disadvantages: the structure of the grid, tied to 50 Hz, as well as the central regulation of electrical power remain as they are.

To substitute the "infinite source of primarily energy" the integration of big, centrally controlled storages is required, which are charged in case of overproduction and discharged in case of over-consumption. In addition, big storages are expensive and have a long planning phase before they can be put into operation.

Furthermore, the production of RE would be higher in some regions than in others, e.g. wind energy will be highest in the north of Germany. The same occurs with consumption, which will be much higher in the south. Thus, more high-voltage transmission lines must be constructed, preferably with DC to avoid losses, resulting in an expensive upgrade of an underlying old grid.

So, what do we need instead? In short, a change in the fundamental operational principles of the electrical grids as they exist today.

A decentralized, self-organizing system, resistant to corruption and fraud, as well as a failure safe and dynamical grid is in order. These are part of the main characteristics of the Quantum Grid.

3. Fundamentals of the Quantum Grid

Basic ideas: power by contract and energy packets

The basic idea of the Quantum Grid is “Energy by contract”. This implies a change from the principle of power on demand to the principle of power by contract (Fig. 2). Then, power is transmitted only if there is an explicit contract between a source and a sink. This contract determines the time when the power transmission starts and ends, as well as the amount of power that should be transmitted at each point in time. This defines a contract of an energy packet.

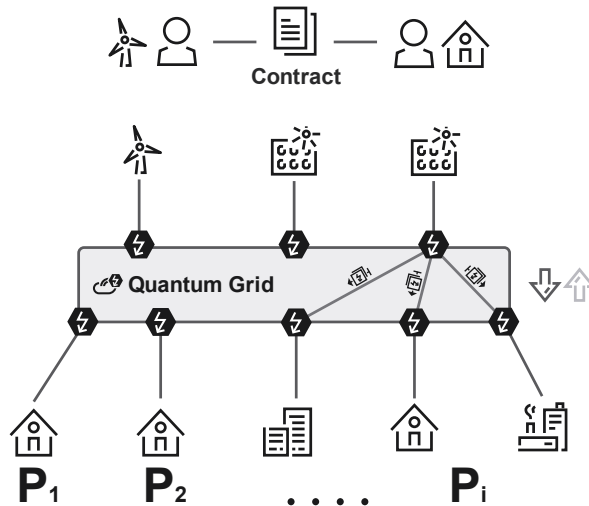

Quantum Grid: Power by contract

- Decentral power supply
- The condition $P_{produced} = P_{consumed}$ must be fulfilled only locally

Fig. 2 The Quantum Grid is operated by a different paradigm: power by contract.

Let’s first look at the definition of an energy packet. Electrical energy is the product of electrical power and the period of time during which this power is available. The transmitted energy is then the integral (sum) of the power over the entire time of transmission:

$$E = \int P(t)dt. \quad (\text{Total energy})$$

As shown in Fig. 3, the power P, as well as the time t, are quantized respectively to an integer multiple, dP and dt. Their product is then exactly one **elementary energy packet**:

$$dE = dP * dt. \quad (\text{Elementary energy packet})$$

An **energy packet** is the sum of all transmitted elementary energy packets from the start of delivery until the end of delivery. Each time interval dt corresponds to a fix value of power, i.e. the value of the power cannot change within one time interval. This is what gives us the power profile of an energy packet. The power profile, also called quantum power flow, is transmitted digitally. Thus, **the Quantum Grid allows the discrete transmission of electrical energy** and is therefore based on packet-based energy transmission.

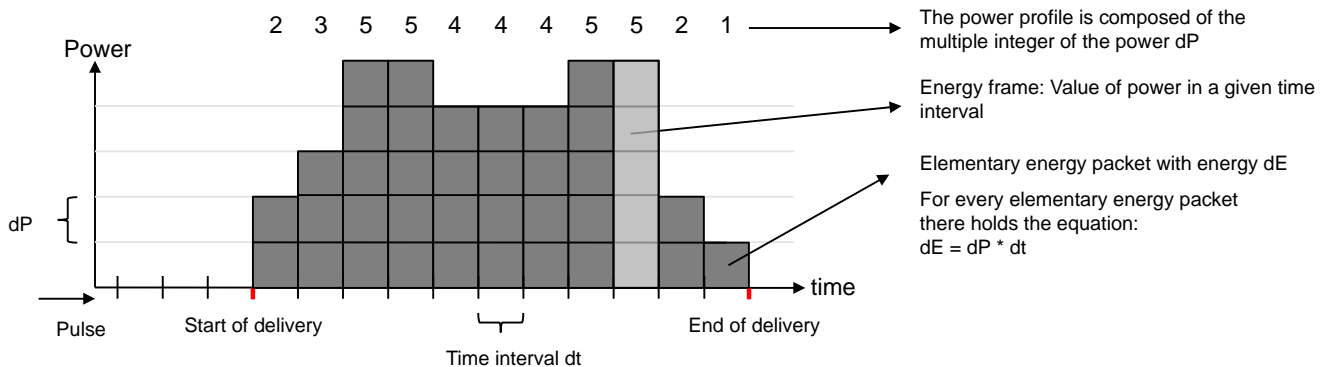

Fig. 3 Power profile: Quantization of power and time that gives rise to the energy packet

The concept of an energy packet is a straightforward generalization of today's energy trading platforms (e.g. EEX in Germany) and the market approach for trading certain energy products for a period of time and constant power (=energy packet). Energy is traded in packets at special trading platforms. They are very coarse-grained and there is no correspondence to the real energy transfer. There is a trend to smaller amounts of traded energy (energy packet), as shown in Fig. 4.

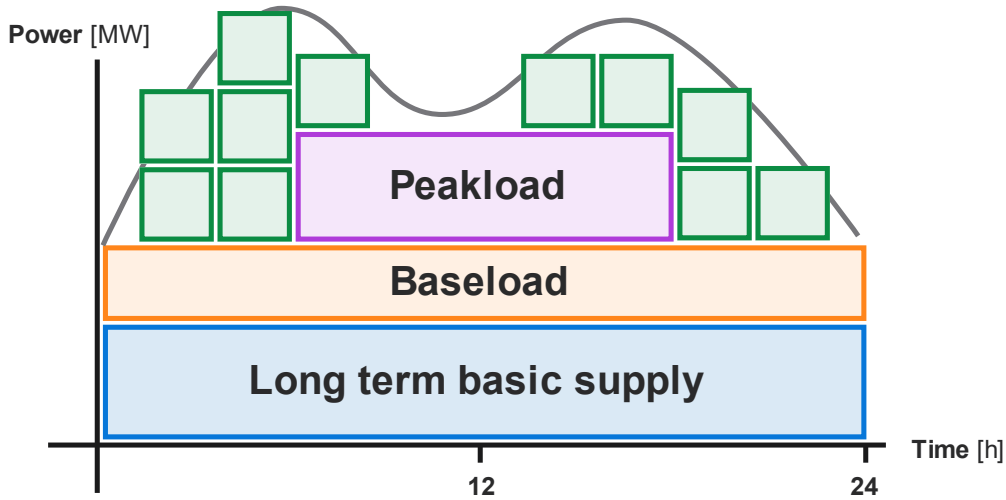

Fig. 4 Load profile of a typical day including traded energy packets. Packets are getting smaller and more grained.

An energy packet is clearly assigned to its corresponding data packet (Fig. 5). The data packet includes all the information of the energy packet, such as the addresses of the source and sink, the start and end time of the power flow, as well as the transmitted power profile. The power profile denotes the value of the electrical power in any time interval. Hence, the data packet of an energy packet contains essential information of the underlying contract.

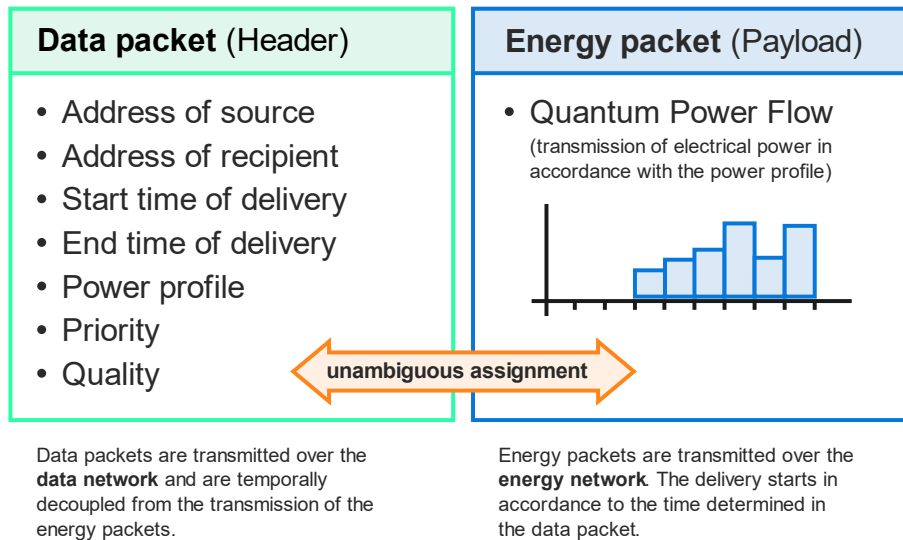

Fig. 5 Data packets and energy packets are unambiguously assigned to each other and are transported through different networks: power grid and telecommunication network.

How can it be ensured, that the energy transmission fixed in the contract will be realized? The key of the power-by-contract operation principle is that the power flow is firmly tied to the contract. Thus, the power flow towards the loads is guaranteed by the contract and forced to take a pre-determined way through the Quantum Grid. To illustrate this in a very simple way see Fig. 6, in which a source is connected to three sinks. The left picture represents a situation in the traditional grid, the right one a situation in the Quantum Grid.

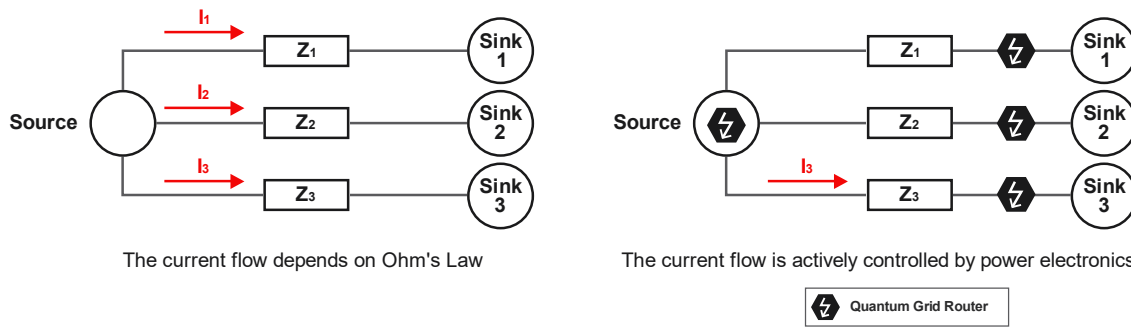

Fig. 6 Left: In a traditional grid, the power flows according to the laws of Kirchhoff and Ohm. Right: In the Quantum Grid, the power flow is controlled and forced to take a pre-determined way at each node in the grid by Quantum Grid Routers.

The source is connected to three identical sinks by transmission lines with impedances Z_1 , Z_2 and Z_3 , being Z_3 the highest impedance. Due to the laws of Ohm and Kirchhoff, the greatest power transmission will take place along the lowest impedance (Fig. 6, left).

If we assume a contract in a traditional grid between the source and sink 3, connected by a line with the highest impedance Z_3 , the power transmission can be insufficient, if sink 1 and 2 are overconsuming and there is not sufficient power available at the source. This means that the contract cannot be fulfilled because of a failed energy transmission.

To enable power by contract it is necessary to assure that the power flow will be transmitted along the desired path to sink 3 (Fig. 6, right). This can be realized by unlocking the transmission lines involved in this path and by blocking all others. Therefore, a switched end-to-end path will be created enabling the contracted power flow. This is similar to the data transmission in the Internet. However, in the internet it is only possible to transmit one data packet at a time along one line per channel.

We do not have this disadvantage in the Quantum Grid, since the power flows in all transmission lines are orchestrated and controlled. This enables a simultaneous transmission of energy packets over the same line at the same time. This process is called **routing or routed packet-based power transmission**, since the energy packets are routed through the Quantum Grid like data packets in the Internet. The devices, which achieve this, are called **Quantum Grid Router (QGR)**, symbolized by the small yellow tons in (Fig. 6, right). They are located in each node of the Quantum Grid.

Before we go into the routing process, let's have a closer look to the functionality of the QGR.

There are several techniques and devices to control or modify the power flow e.g. modified inverter technology, FACTS, phase shifting transformer, etc. Thus, the power flow can be forced along a pre-determined path, which does not have to correspond to the path given by Ohm's Law.

In the Quantum Grid, the control of the power flow occurs with the help of inverter technology based on modern power electronics (PE) located in the QGR. The power transmission can then be forced along at least one path, which connects source and sink. The QGR is the core element of a packet-based electrical transmission grid, enabling the transmission of energy packets from a sender through the grid to a receiver over a pre-determined path.

A QGR consists of ports connected externally to consumers, producers, storages and grids. Inside a QGR, the ports are connected by a DC-bus, as shown in Fig. 7. Every port holds a power electronic device called Quantum Flow Controller (QFC). This is an essential element of the QGRs, as they are responsible for the control and routing of the power flow.

Generally, multiple paths from a source to a sink exist in a Quantum Grid. Because the power flow is now independently controllable and strongly deviating from the classical impedance dominated power flow, the path for the energy packet needs to be actively determined. The optimal path is selected by intelligent path-finding and optimization algorithms like the Dijkstra-algorithm [6], Bellman-Ford algorithm [7, 8] or other well-known link-state or distance-vector routing protocols.

The Dijkstra algorithm is an algorithm, developed by Edsger W. Dijkstra and published in [6], which finds the shortest path (or optionally, the optimal path with the lowest costs) between a source and all sinks in a graph. Similar are the Bellman-Ford and other path-finding algorithms.

The routing process will be explained in more detail in the section “Routing in the Quantum Grid” after we had a look at the physics beyond the routed packet-based power transmission in “Quantum Grid Physics” and how the Quantum Grid is built up in the section “Architecture of the Quantum Grid”.

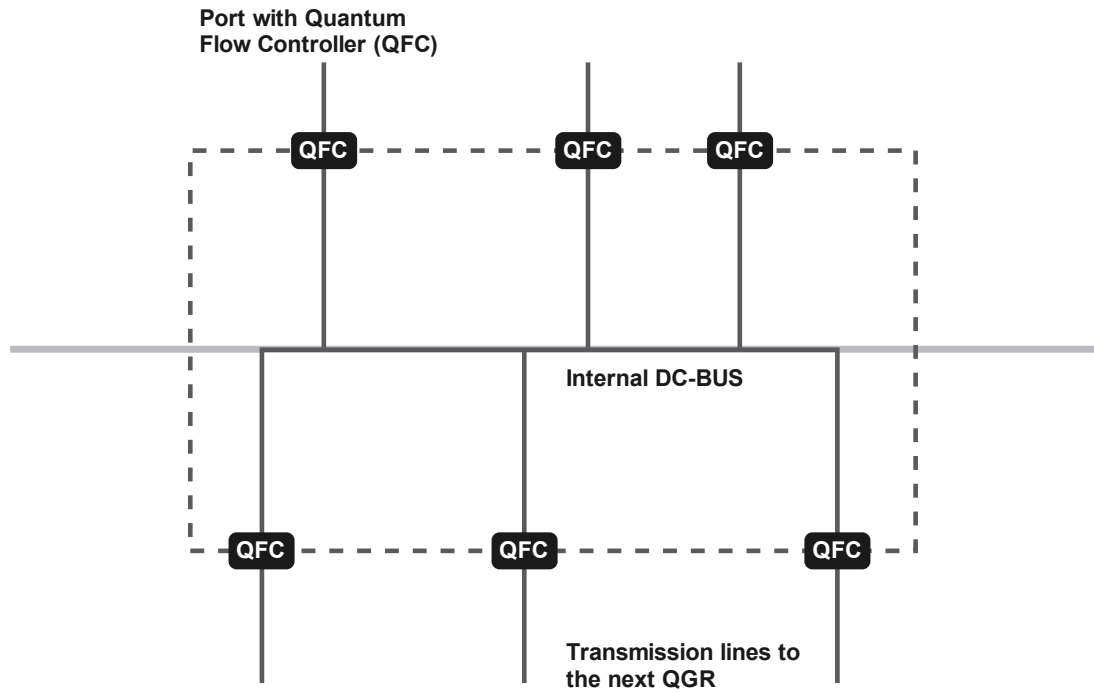

Fig. 7 Quantum Grid Router with six ports, each one containing a QFC. The QFCs are connected to the internal DC-bus.

4. Quantum Grid Physics

In this section, we want to discuss the fundamental physics of the Quantum Grid and point out the difference to the classical grid physics where the routing of the power flow is determined only by Ohm's and Kirchhoff's laws. Hereafter, bold letters denote vectors.

First, a brief look is taken to electrodynamics and Ohm's law will be expressed with the help of the electric field.

If an electric field \mathbf{E} is applied to a conductor, a current density \mathbf{j} will be produced. If there is a linear relation between \mathbf{E} and \mathbf{j} , it is called Ohm's law:

$$\mathbf{j}(\mathbf{r}) = \sigma \mathbf{E}(\mathbf{r})$$

The electric conductivity σ is a material constant and can only be determined by experiment. Ohm's law is an empiric law. To get its well-known form, $U = I \cdot R$, the integral over a determined length $\Delta \mathbf{r} = \mathbf{r}_2 - \mathbf{r}_1$ must be calculated:

$$\int_{r_1}^{r_2} \mathbf{E}(\mathbf{r}) d\mathbf{r} = \int_{r_1}^{r_2} -\nabla\Phi \cdot d\mathbf{r} = \int_{r_1}^{r_2} -d\Phi = \Phi(r_2) - \Phi(r_1) = U$$

In the second step, it was used, that in electrostatics the electric field is given by the gradient of the scalar potential Φ . In the third step, the scalar product of the gradient $\nabla\Phi$ and the differential vector $d\mathbf{r}$ gives the total differential of the potential, $d\Phi$. The integration leads to the potential difference, which is exactly the voltage U applied to the conductor. Note that, ∇ is called the nabla operator, which is defined in terms of partial (spatial) derivatives:

$$\nabla = \left(\frac{\partial}{\partial x}, \frac{\partial}{\partial y}, \frac{\partial}{\partial z} \right)$$

On the left hand of Ohm's law, the same should be performed. Instead of the electric conductivity σ , the resistivity $\varrho = \sigma^{-1}$ is used:

$$\int_{r_1}^{r_2} \varrho \mathbf{j}(\mathbf{r}) \cdot d\mathbf{r} = \int_{r_1}^{r_2} \varrho j dr = \varrho I \frac{l}{A} = I R$$

Since the current density is parallel to the conductor line, vectors can be omitted. Using $j=I/A$, where I is the current, A is the cross-section area of the conductor and $\int_{r_1}^{r_2} dr = l$ is the considered line length, Ohm's law as it is known is obtained:

$$U = I R$$

Note that, Ohm's law holds for any ohmic resistance.

The Quantum Grid will be formed by the active physical elements (QGR) and the routed packet transmission, which is enforced by the "quantized" control of the power flow. The control of the power flow inside the QGR is enabled by the fundamental electrodynamical principles described by Maxwell's equations. To see the relationship between currents and fields, the covariant, four-dimensional representation of (the inhomogeneous) Maxwell equation gives the most elegant and simplest form:

$$\partial_\mu F^{\mu\nu} = \mu_0 j^\nu \quad (1)$$

where the left side contains the derivatives of the electric and magnetic field, \mathbf{E} and \mathbf{B} , and the right side gives the current.

The homogeneous Maxwell equation is fulfilled as well:

$$\partial_\mu \hat{F}^{\mu\nu} = 0 \quad (2)$$

The field strength tensor $F^{\mu\nu}$ and the dual field strength tensor $\hat{F}^{\mu\nu}$ contain the electric field $\mathbf{E} = (E^x, E^y, E^z)$ and the magnetic field $\mathbf{B} = (B^x, B^y, B^z)$:

$$F^{\mu\nu} = \begin{pmatrix} 0 & -\frac{1}{c} E^x & -\frac{1}{c} E^y & -\frac{1}{c} E^z \\ \frac{1}{c} E^x & 0 & -B^z & B^y \\ \frac{1}{c} E^y & B^z & 0 & -B^x \\ \frac{1}{c} E^z & -B^y & B^x & 0 \end{pmatrix} \quad \hat{F}^{\mu\nu} = \begin{pmatrix} 0 & -B^x & -B^y & -B^z \\ B^x & 0 & \frac{1}{c} E^z & -\frac{1}{c} E^y \\ B^y & -\frac{1}{c} E^z & 0 & \frac{1}{c} E^x \\ B^z & \frac{1}{c} E^y & -\frac{1}{c} E^x & 0 \end{pmatrix}$$

Equations (1) and (2) express the relevant physical principle of a QGR and can also be read in reverse. Changes of the fields induce currents and currents lead to fields. The fields can be stored in electro-magnetic elements in the Quantum Grid, such as inductors and capacitors.

In the following, it will be explained in detail how to describe the relationship between the changes of fields with densities of charge ρ and current \mathbf{j} , given in the covariant formalism by the 4-vector $j^\nu = (c\rho, \mathbf{j})$ (c is the speed of light). The fundamental field in electrodynamics is the 4-potential (4 = four-dimensional, space and time):

$$A^\mu = \left(\frac{\Phi}{c}, \mathbf{A} \right)$$

Here, the upper index denotes a contravariant tensor, which differs from a covariant tensor (with lower index) in its transformation properties. The Greek letter Φ denotes again the scalar potential and \mathbf{A} the vector potential. These potentials are deeply related to the magnetic and electric field, \mathbf{B} and \mathbf{E} , by:

$$\mathbf{B} = \nabla \times \mathbf{A} \text{ and } \mathbf{E} = -\nabla\Phi - \frac{\partial \mathbf{A}}{\partial t}$$

Note that, in the case of electrodynamics, \mathbf{E} contains not only the gradient of the scalar potential, but also the time derivative of the vector potential.

The 4-gradient ∂_μ contains the temporal and the spatial (the nabla operator ∇ defined before) derivatives:

$$\partial_\mu = \left(\frac{1}{c} \frac{\partial}{\partial t}, \frac{\partial}{\partial x}, \frac{\partial}{\partial y}, \frac{\partial}{\partial z} \right) = \left(\frac{1}{c} \frac{\partial}{\partial t}, \nabla \right) .$$

Through the derivatives of the 4-potential, the field strength tensor is defined as:

$$F^{\mu\nu} = \partial^\mu A^\nu - \partial^\nu A^\mu$$

The dual field strength tensor can be constructed as:

$$\hat{F}^{\mu\nu} = \frac{1}{2} \varepsilon^{\mu\nu\alpha\beta} F_{\alpha\beta}$$

where $\varepsilon^{\mu\nu\alpha\beta}$ is the four-dimensional Levi-Civita-Tensor. For its definition, see [9]. For a deeper understanding, the inhomogeneous Maxwell equations, which are the relevant ones for the Quantum Grid, are derived from eq. (1) and written in its classical form:

$$\nabla \cdot \mathbf{E} = - \frac{\rho}{\varepsilon_0}$$

$$\nabla \times \mathbf{B} = \mu_0 \mathbf{j} + \mu_0 \varepsilon_0 \frac{\partial \mathbf{E}}{\partial t}$$

Here clearly can be seen, that currents and charges cause fields and vice versa. This is what happens in the inductors and capacitors implemented in the power converter when the switch is closed or opened, thus generating fields that are built up or broken down.

From this, the energy stored in an electrical device can be obtained. The electric field between the plates of a charged capacitor is a store for electrical energy. An inductor with magnetic field due to a current I flowing through the coil acts as a storage for magnetic energy. Both can be extracted again without significant thermal loss. A calculation of the stored energy can be found in any student's book in physics, e.g. [10].

This feature is used to control the power flow inside the Quantum Flow Controller (QFC) and to enable the transformation of voltage and current. For illustration purpose, see Fig. 8:

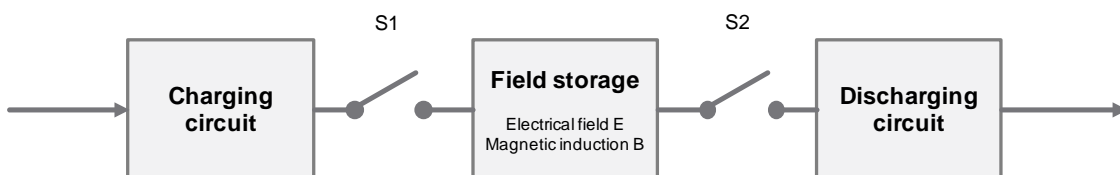

Fig. 8 Power Converter setup.

In general, the process is divided into two phases: *charging/loading* and *discharging/unloading*: While charging, switch S1 is closed and S2 is open. The current will generate a change in the field of the storage device as described by Maxwell's equation. Typically, inductors are used for magnetic field storage and capacitors are used for electric field storage, as they are found in typical buck-boost

(B-field), dual active bridge (B-field) or charge pump (E-field) converter topologies. While discharging, S1 is open and S2 is closed allowing the changing field to generate a current again.

By properly designing charging and discharging circuits, different power converter topologies can be realized to convert between DC/DC and AC/DC at different voltage levels.

Control of the switching period of the power e.g. by PWM realizes the desired power flow. Central elements of the power electronics are controllable electronic switches, based on the solid-state quantum mechanical properties. Therefore, high switching frequencies (>10 kHz) can be achieved.

Now a closer look to an AC-grid is taken. By using the properties of the inverter technology, the QGR can deliver different output voltages as well as change the phase independently. This allows a flexible modelling of the energy packets by controlling the power flow and will be shown in the following. This consideration is similar to those of R. Abé et al. in [5]. For this the power flow through two types of grids, as shown in Fig. 9 are studied:

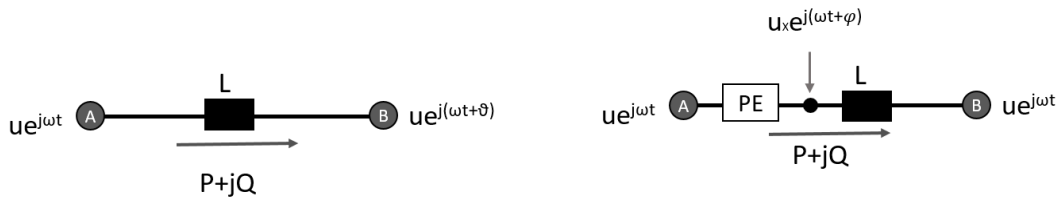

Fig. 9 Representation of a transmission line in a synchronous grid (left) and equipped with a PE to control the power flow grid (right).

Fig. 9 (left) shows two AC grids, A and B, with the same frequency and voltage, but phase shifted by the angle ϑ . The grids A and B are connected by a line with inductivity L.

Fig. 9 (right) shows two AC grids A and B with the same frequency and voltage. For simplicity, a phase shift is omitted here. The grids A and B are connected by a line with inductivity L and an inverter, which synthesizes a voltage $u_x e^{j(\omega t + \varphi)}$.

In a traditional grid, there are no degrees of freedom to control the power flow. By calculating the power flowing from A to B in the left picture of Fig. 9, we obtained for the active power P and the reactive power Q the expression:

$$P + jQ = \frac{u^2 \cdot \sin \vartheta}{\omega L} + j \left(\frac{u^2 \cdot \cos \vartheta - u^2}{\omega L} \right)$$

The active and reactive power flow is in principle given by the angle ϑ , which denotes the phase shift between the two grids A and B. It cannot be controlled, whereas the power flow using power electronics (right picture of Fig. 9) is given by

$$P + jQ = \frac{u \cdot u_x \cdot \sin \varphi}{\omega L} + j \left(\frac{u \cdot u_x \cdot \cos \varphi - u^2}{\omega L} \right)$$

It has two degrees of freedom, u_x and φ , so that the PE can control the active and the reactive power independently. Hence, energy packets with the desired power profile can be formed.

5. Architecture of the Quantum Grid

The architecture of the Quantum Grid is a lot more complex than the structure of the Internet, since energy transmission (power flow), communication (data packets and routing) and business (contracts) are involved. The core features of the Quantum Grid are contracting, routing and a physical end-to-end controlled power flow naturally leading to the following 3-tier architecture shown in Fig. 10:

1. Business Plane
2. Routing and Routing and Control Plane
3. Power Plane

First, we want to point out the main tasks of each plane:

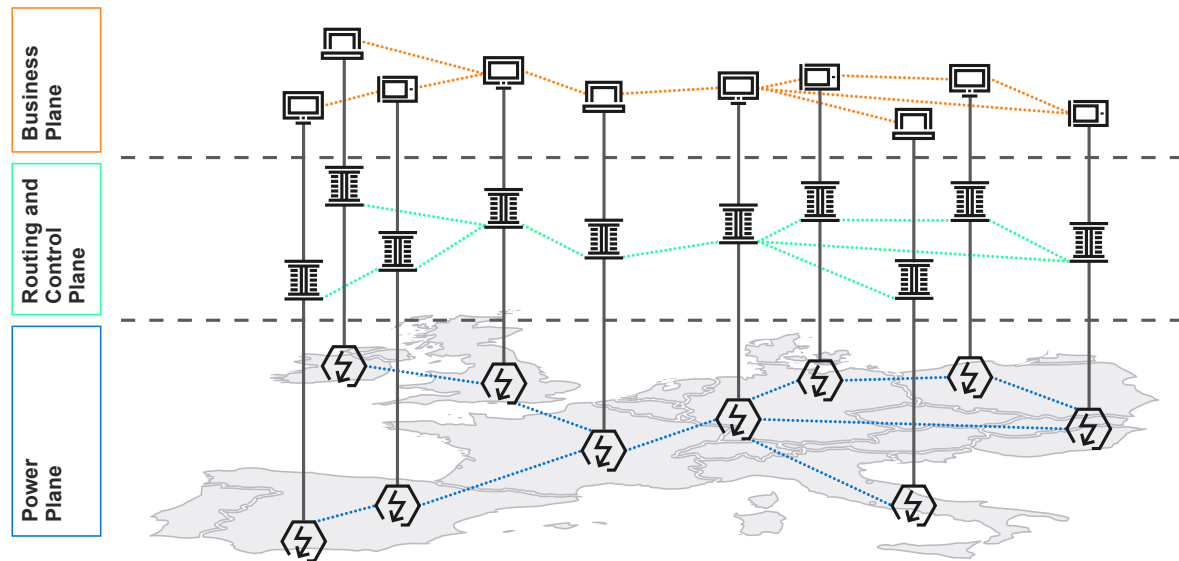

Fig. 10 Three-layer architecture of the Quantum Grid: Business Plane, Routing and Routing and Control Plane and Power Plane.

Business Plane

- Auction: a trading platform where energy producers can place their offer and consumers can search for a suitable energy packet provider.
- Matching of producer and consumer.
- Power Blockchain as a transparent and decentral logbook for transactions [11].
- Contract consolidation: the contracts directly correlate with the transmitted energy packets.
- Energy packet order-management.

Routing and Control Plane

- Finding the optimal path between source and sink by the use of path-finding algorithms (Dijkstra, Bellman-Ford, etc.).
- Managing the data packets associated with the energy packets.
- Scheduling of energy packets.
- Routing and forwarding of data and energy packets.
- Selecting the right port.
- Communicating between the nodes and the planes.
- Assembling, transmitting and disassembling of transport packets.
- Line capacity management as well as the estimation of transmission losses.
- Performance management and operational support and readiness (OS&R) functionality.
- Fault management.
- Re-routing in case of disturbances.

Power Plane

The Power Plane represents the physical grid. Here the packet based electrical power is transmitted from the sender to its recipient. The Power Plane contains the lines and the QGRs. For details, see section “Power Plane and QFC embodiments”. We also recommend [12].

6. Routing in the Quantum Grid

The Routing and Control Plane is purely based on Software Defined Solutions¹ on standard computer hardware.

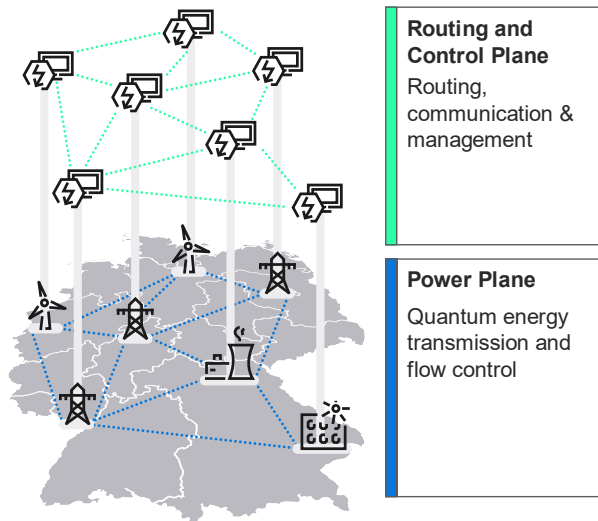

Fig. 11 Routing and Control Plane and Power Plane. The Power Plane consists of the physical transmission lines, the prosumers and the QGRs. The Routing and Control Plane is responsible for communication, routing, etc.

Data packets in the internet have a header and the payload. The header carries information about the emitter, the recipient, the length, the number of hops and the data (payload). Similarly, the energy packets in the Quantum Grid have a uniquely associated data packet that carries information about emitter, recipient, power profile, priority, contract data and security features.

Power routing and power transmission occur at the control and the Power Plane (Fig. 11). The job of the Routing and Control Plane is to find the best route for the power transmission and to manage the associated data packets, the communication between the nodes and the scheduling of energy packets. Furthermore, the Routing and Control Plane is responsible for assembling, transmitting and disassembling of transport packets, which we describe further.

The Power Plane represents the physical grid, where the electrical power is transmitted from the sender to its recipient. The power flow takes the pre-determined, optimal route. This must not coincide with the route dictated by Ohm and Kirchhoff, which is the one with the minimal impedance.

The forcing of the power flow to take a determined route is the fundamental difference to the existing grid.

Before the transmission of the energy packet at the Power Plane starts, its assigned data packet travels through the Routing and Control Plane and ensures perfect routing of the energy packet. The transmission of the energy packet is realized at a later point in time that is set by the information in the data packet. The energy packet is then forwarded, following the path determined previously by intelligent algorithms¹. The algorithm determines the costs for the transport between all participating hops (QGR). Each QGR stores the information about where the energy packet should be sent next. Due to the information of the data packet, the QGR knows which amount of power it should set for a determined energy packet and the time of transmission. This is visualized in Fig. 12.

¹ Designed and in process of developing by GIP.

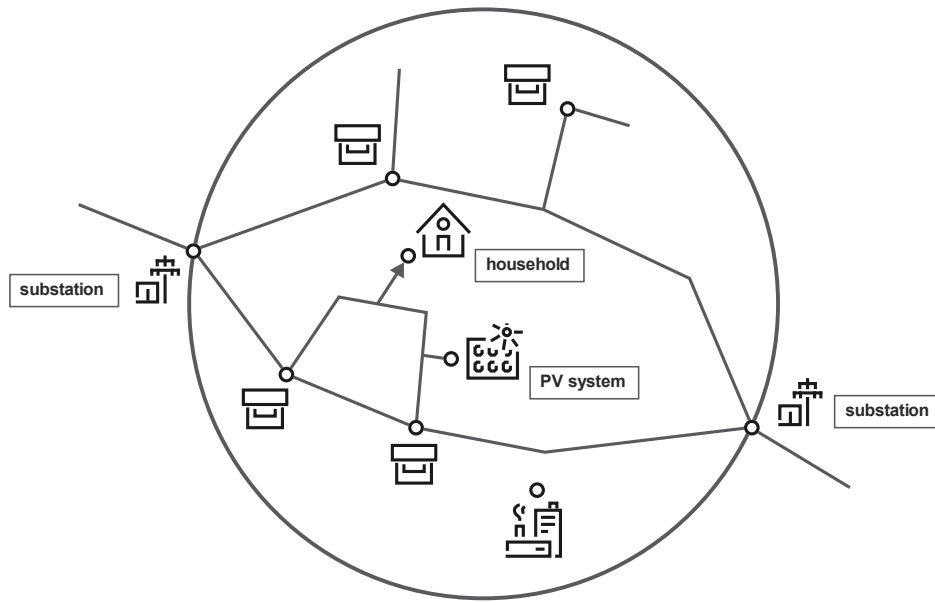

Fig. 12 Routed electrical power

In case of a damaged or overloaded line, the Routing and Control Plane immediately finds, if possible, another route for the energy packet. The probability of a failure of the entire grid tends to be zero. The routing is self-organizing. If QGRs are added or removed from the grid, the system recognizes these changes without the support of a central server.

As mentioned before, the Routing and Control Plane is completely software defined. Its key feature is to realize the routing logic and execute the Quantum Grid routing algorithm. Fig. 13 shows the steps included in this algorithm. Each step will be explained below.

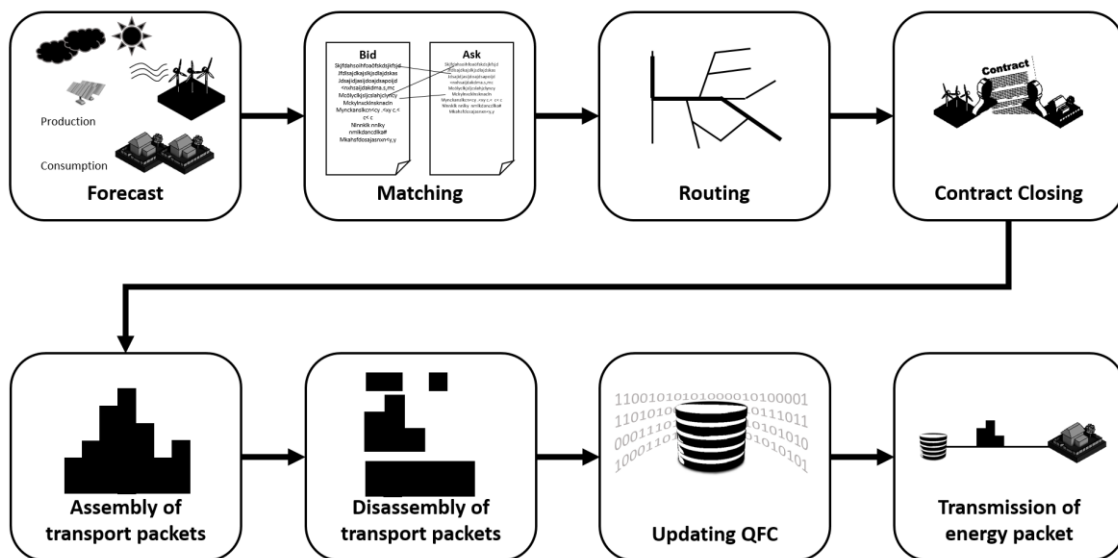

Fig. 13 Visualization of the steps of the Quantum Grid routing algorithm.

Forecast: The Routing and Control Plane contains an energy management system, which handles two important aspects of this plane: the diagnosis and forecast of energy production and consumption, as well as transmission losses. The energy management includes sensor data processing and packet statistics. Based on this, it generates a forecast for the production and consumption, which is required for the energy packet ordering via the market platform (on the Business Plane).

Matching: The Business Plane generates a matching list of potential sources and sinks which can fulfil “contracts”.

Routing of energy packets: Intelligent routing algorithms calculate an optimal path between the source and the sink for every matching. Determining factors are the transmission costs and the transmission capacity.

A path between the sink and the source consists of links between QGRs in the grid, which yield an end-to-end connection. When the best path is found, it will be reserved for these particular matching partners.

Transmission costs of a path are basically line losses as well as losses for every passed port. Further operational expenses (OPEX) and capital expenses (CAPEX) have to be added to the overall transmission costs.

Contract closing: After reserving the transmission capacity and determining the transmission costs, the contract between the transmitter and the receiver of the energy packet is finally closed.

Within the Quantum Grid, the data set in the contract is transduced in quantities of elementary energy packets. The consumers do not pay a global static network charge anymore; they simply pay the real transmission costs of the energy packets. For example, the direct charging of transmission losses could promote the purchase of locally produced energy with obvious economic advantages.

This is only possible when energy is handled in form of energy packets.

Assembly of transport packets: The Routing and Control Plane includes a transmission and queuing management, which collects from the data packet the information of the energy packet. The Routing and Control Plane selects the inbound and outbound ports and adds the energy packets to the so-called packet queue. Energy packets, which take the same way, are added to form **transport packets**, so they could be transmitted together over the same line at the same time. We explain this in detail in the next section.

Disassembly of transport packets: At the end of the simultaneous transmission, the transport packet has to be split back into the original packets, which will then be separately transmitted to their original destination addresses.

Updating QFCs: Then, the quantized profiles are submitted piecewise to the controller of the PE (QFC). The Routing and Control Plane controls incoming and outgoing power flows for all ports. The synchronized transmission requires a common grid time across all QGRs.

Note that, the main difference to the existing grid is that the QGRs formulate a schedule of their demand. Each schedule is guaranteed by contracts. A rejection of ordered power by the customer will incur a penalty. The same procedure will take place when there is a failure in delivering energy. In order to avoid this, the prosumer can buy his own private energy storage device. Local, decentralized and managed storages become more attractive in such a scenario. In addition, the falling prices for storage solutions will increase the usage at the customer site.

The Quantum Grid consists of QGRs that are logically connected, thus building a path between producer and consumer and storages, if available. If consumer and producer conclude a contract, the power flow starts at the appointed time. A determined number of energy packets covers the individual demand. This contract is the prerequisite for the power flow and the connection of the nodes in the grid. If no energy packets were ordered in advance, the customer remains without current. In addition, the producer can only supply power if he has a contractual agreement with the customer. Each contract represents the basis for the connection of the nodes over the energy packet. In contrast to today's mechanism, in a Quantum Grid scenario, both, producer and consumer will get more responsibility to cover the grids stability.

A main advantage of a routed electrical grid is its ability to perform a rerouting of the affected energy packets in case of a failure. Fig. 14 illustrates a routing example in case of a malfunction of a line. Under normal conditions, the routing will prefer the path with the lowest transmission cost (usually given by the losses and number of hops), which has become the reserved path in the first place. In the event of a failure of one line, the energy packet delivery will be interrupted and the algorithm determines an alternative path. The last picture of Fig. 14 shows additionally the simultaneous transmission of the rerouted energy packet and an energy packet released by another source. We explain this process in detail in the next section.

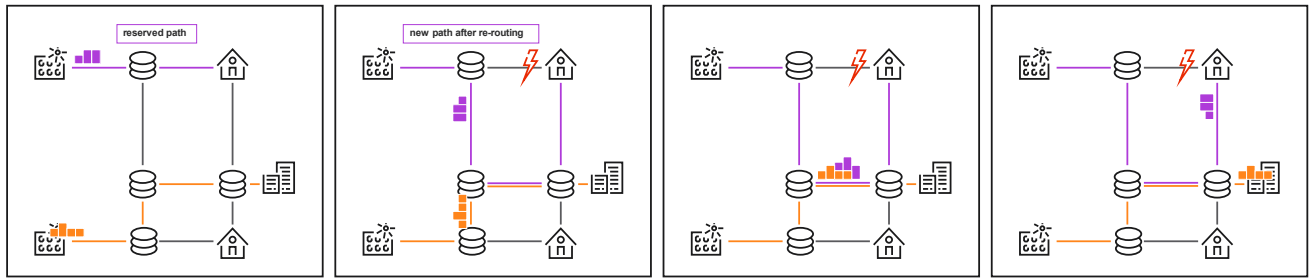

Fig. 14 Left to right: The energy packets are released by the sources; The routers know the interface which lead to the correct path; In case of failure, the packets are re-routed; Thus obtaining a failure safe Quantum Grid

Simultaneous transmission of energy packets in detail: transport packets

We want to emphasize again that the main difference between the Quantum Grid routing and the Internet routing is the simultaneous transmission of packets along one line. In the internet data packets have to be transmitted sequentially, there is no mechanism to put them together. The internet routing is based on the principle of storing and forwarding, where the data packets are forwarded one by one depending on certain prioritizing factors.

Because of the physical superposition principle, electromagnetic fields and currents can be added and thus energy packets can be transmitted along one line at the same time. A new packet type, the transport packet, is required. A transport packet is formed by adding all packets that have an overlap in the transmission time. When adding the packets, the direction of the packet flow has to be taken into account by assigning the right sign to the amplitude of the packet. Fig. 15 illustrates the transport packet generation for a simple example.

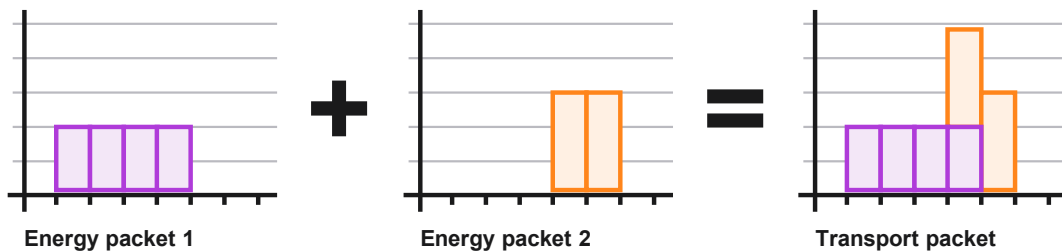

Fig. 15 Addition of two energy packets to one transport packet

How exactly does the transmission of energy packets take place? For illustration purpose, a specific example will be discussed in the following. In this particular example we show, that not only the amount of power but also the direction of the flow has to be taken into account.

In Fig. 16 a filled order queue of a QGR is shown on the left side. It contains the information of the energy packet (simplified for clarity) and the receiving and sending ports (A-F). The filled order queue is the local result of the globally performed routing along the optimized path through the Quantum Grid. On the right side, the internal power flow for every energy packet within a QGR is indicated. The ports are internally connected via a DC-Bus.

In the example, the order queue contains a record saying that at the time $t = 0$ a power packet of 10 kW is supposed to be sent from port A to port E. In the next time interval, $t = 1$, B and E deliver 5 kW to E and D, respectively. The red arrows on the right side symbolize this.

The example illustrates the packet transmission (C to F), the combination of transport packets (A to E and B to E) as well as counter propagating energy packets (E to D).

Order Queue

Source	Dest.	Time	Length	Profile
A	E	0	1	10
B	E	1	1	5
C	F	2	1	2
E	D	1	1	5

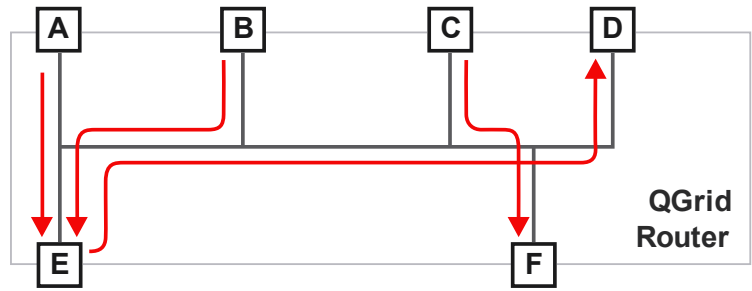

Fig. 16 Left: Order queue, which lists the energy packets that are sent from port to port within the QGR for each time interval. Right: QGR with six ports and power flows visualized by red arrows.

Starting with the order queue, the energy packets are inserted into the packet queue of each port. Fig. 17 shows the packet queue with the recorded power flows given by the power profile in the data packets.

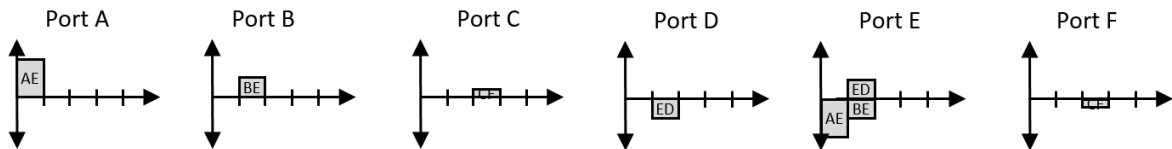

Fig. 17 The power flow through each port is recorded in the packet queue on the Routing and Control Plane (idealized, without losses).

Considering the ports A and E, at the time $t = 0$ A sends 10 kW to E and E picks up 10 kW. An entry in the order queue always includes at least two parts, a negative value for sending and an exactly equivalent positive value for receiving. The sum at $t = 0$ from power flowing in and flowing out is exactly zero.

The same happens for $t = 1$: B sends 5 kW to E, and E sends 5 kW to D. That means in effect, that port E does not do anything at $t = 1$, whereas B sends 5 kW to the bus and D takes it from there. The real power that is transferred is what we call a transport packet. Note that it does not necessarily coincide with the entries in the order or packet queue.

The transport packets are shown in Fig. 18. They were introduced in order to solve the problem of the simultaneous transmission of energy packets along the same lines. The key issue is that individual packets can be added up to transport packets and sent along the port or line at the same time. In the given example, the only difference between Fig. 17 and Fig. 18 is in port E, where the outgoing and ingoing energy packets at time $t = 1$ are of the same size and thus add up to zero, thus emphasizing the importance of the direction of the power flow.

When the transport packets reach their target port, they can be disassembled again. The Routing and Control Plane is responsible for the assembling and disassembling of transport packets.

The Power Plane is a network consisting of the bus and the connected transmission lines. Consequently, every single energy packet passes the bus and the generation of transport packets happens automatically. The transport packets TP at each port m are defined as the sum over all n packets P_l (l being the summation index which counts the number of energy packets for each time step) at a given time t_j . Thus, at each port it is fulfilled that:

$$\sum_{l=1}^n P_l(t_j) = TP_m$$

A QGR satisfies the contract between source and sink: it generates exactly the number of energy packets ordered. Consequently, the sum of transport packets over all ports at a fixed point in time is zero. This is an intrinsic property of the QGR:

$$\sum_{m \text{ ports}} TP_m(t_j) = 0$$

Transport-Paket Queues

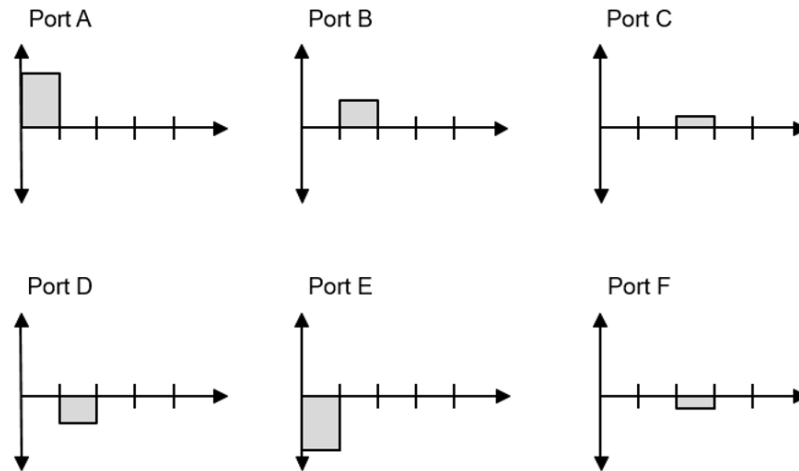

Fig. 18 Transport packets: real power transmitted (here: without losses).

We see in Fig. 18 that at any time the transport packets sum up to zero, e.g. at t = 0 the TPs of A and E, at t = 1 the TPs of B and D, etc.

7. Power Plane and QFC embodiments

Now that we know how the physics works, let's have a look at the physical devices which realize the power flow control at each port, the QFCs (key elements of the QGRs).

There are many approaches to control the power flow. We first discuss two possibilities to control and convert a DC voltage in the Quantum Grid.

One possible realization of such a DC/DC converter could be a **buck-boost converter** with a 4-switch topology (Fig. 19). The switch positions vary periodically, creating a voltage with a rectangular waveform with period T_{switch} . This period is inversely proportional to the switching frequency (typically 1 kHz-1MHz). The switches can be realized by using semiconductor devices such as diodes, MOSFETs, IGBTs or thyristors.

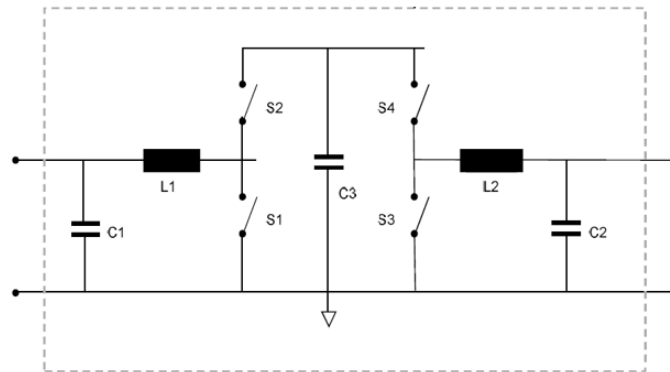

Fig. 19 Buck-boost converter: a bidirectional power flow control device.

Another possible realization of a DC/DC converter would be a **Dual Active Bridge** (DAB, Fig. 20) [13] [14], [15], [16]. The DAB can be connected on both sides to DC-grids with different voltage levels. Suppose that at a time t electrical power should be transmitted from grid 1 to grid 2. The DC voltage is converted into AC voltage with a high frequency² in the upper converter. The transformer changes the value of the voltage. In the upper converter, which acts as a controlled rectifier in this moment, the AC voltage is transformed again into DC voltage. This is fed into grid 2³. Note that in the DAB, an AC voltage with very high frequency is used inside to control a DC voltage in the grid. Such a high frequency is advantageous because it drastically reduces the size of the coils and thus, it is material and cost saving.

In addition, there are two measure systems, which together with the converters are connected to the control unit. The control unit in turn is able to communicate with the Routing and Control Plane. From there it gets the set points of the power profile of the energy packet to be transmitted and sets the configuration of the QFC in accordance with this data. The measure systems measure the real transmitted power. The DAB now acts as a control loop viz. as a QFC: it receives the actual value and adjusts it, in case it does not meet the desired value.

Physically, the power flow is regulated by a phase shift between the voltage of primary and secondary coils. The transmitted active power depends on this angle. This is the way the feeding of power into the grid works nowadays.

² The higher the frequency, the smaller the size of the transformer, minimizing thus the costs for material.

³ If grid 2 happens to be also an AC grid, the DC voltage has to be transformed once again in AC voltage with the right frequency.

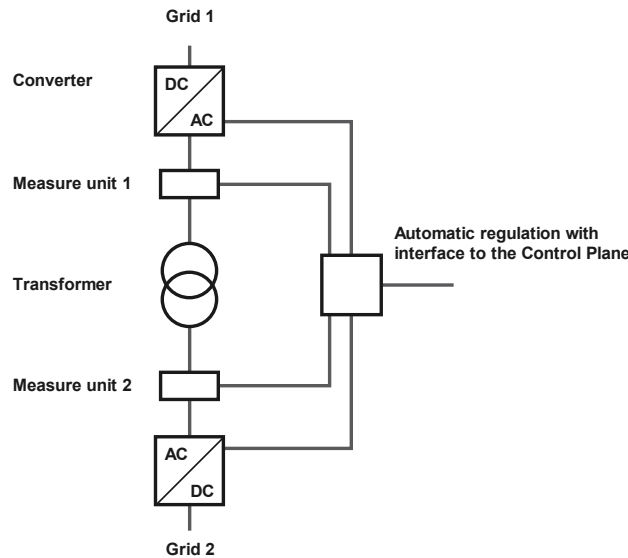

Fig. 20 Insight into a QFC: the DAB is responsible for the bidirectional DC/DC conversion.

The group of Prof. A. Sumper (CITCEA research group from the Universitat Politècnica de Catalunya in Barcelona) developed a QGR [12], which controls AC voltage by performing an independent regulation of the active and reactive power flow with **voltage source converters** at each port (Fig. 21). In addition, this technology allows operating different types of AC and DC technologies asynchronously. This way it is possible to merge grids of different topologies, connecting three-phase systems with single-phase or DC lines.

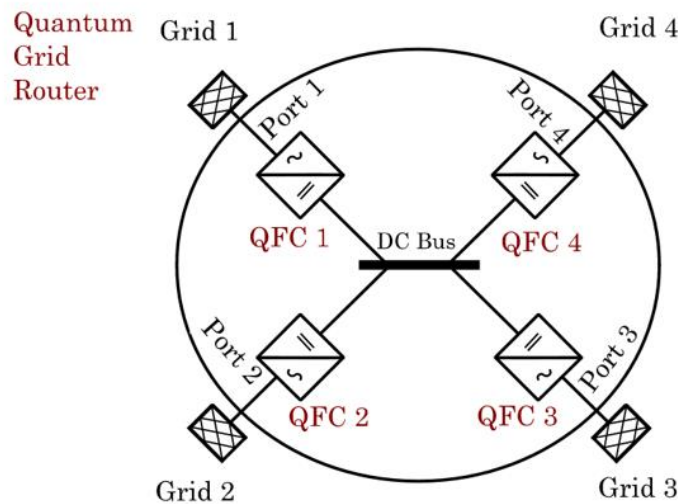

Fig. 21 Example of a 4-port Quantum Grid Router designed by the group of Prof. Sumper at the UPC in Barcelona. (By courtesy of Prof. Sumper)

8. Storages in the Quantum Grid

The generation of electrical energy in a grid, where a large number of renewable producers are involved, is subject to huge fluctuations. There are predictable variations due to summer/winter, day/night, but also less predictable values like wind speed, solar radiation, clouds, etc. Furthermore, also the consumption of energy is changing and has to be predicted as precisely as possible.

To ensure a stable power supply, the power provided must always be equal to the power demanded. Therefore, storage elements are indispensable. In a modern power grid with a multitude of renewable sources, but no storages, stable power supply could not be guaranteed.

As part of its research activities on the Quantum Grid, the GIP has applied for a patent describing the orchestration of sources and sinks for the grid stability, as well as the dynamic management of distributed storages [17].

Two scenarios are in order: the power required by the consumers is either higher or lower than the power provided. Buffer storages are supposed to balance deficits or excesses of power as well as the resulting emergencies.

Nowadays arguments focus on the need of expensive, huge, central storages, which are able to provide a large amount of energy, and which have big losses, making this approach senseless.

For the Quantum Grid, the situation may be different: a multitude of storage elements of any size is possible. Small storages for the smaller producers and for consumers, bigger ones for bigger producers such as wind parks or solar parks. The storages are located at different places and could be used by one or more participants, which can be anywhere in the grid. This is possible thanks to the intelligent orchestration of sources, sinks and storages. In the energy management of the Quantum Grid, also cloud-storages are an option.

Some tasks of the storages are:

- a. to bridge a long-term period (e.g. caused by seasons),
- b. to balance short-term imbalances,
- c. to storage energy packets in times of high production rate,
- d. to supply power to mobile devices.

In the Quantum Grid, the buffer storages are integrated in one or more ports of the power routers. They are designed in such a way that both, its maximum electrical power and its maximum power consumption can be calculated for future times. This information also includes data such as charging, discharging and temperature-dependent behavior.

Fig. 22 shows the process of storage: physically on the Power Plane (left) and by means of routing on the Routing and Control Plane (right). Of course, at the endpoint consumer can be located, as well as combinations of consumer and storages.

Thus, it is possible to supply power to various storages from only one source. Vice versa, various storages can provide the power profile for one customer. This intelligent orchestration is only possible due to the packet-based nature of the energy in the Quantum Grid.

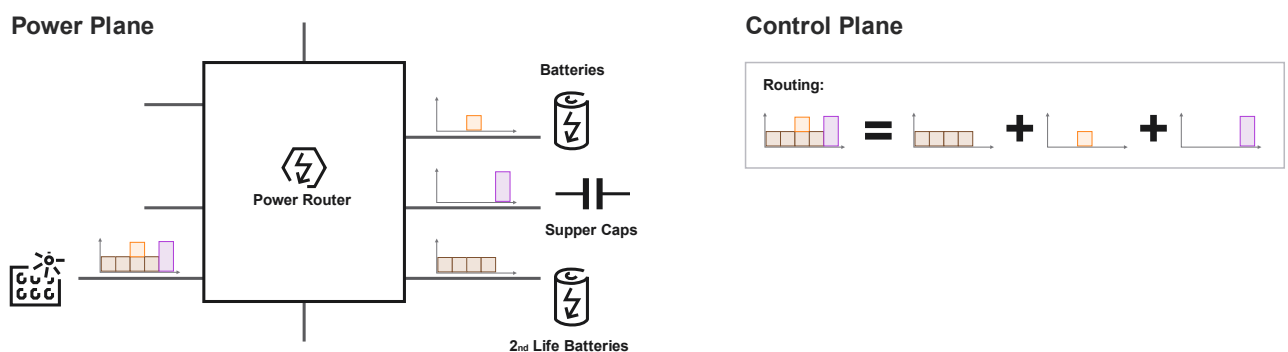

Fig. 22 Intelligent orchestration of storages at the Power Plane due to routing on the Routing and Control Plane.

Each producer can either store his surplus of energy in an own storage element or sell it to a customer who wants to buy energy packets in advance. In addition, a common use of one storage of both consumer and producer is possible. A consumer should not be forced to buy his own storage, but should have access to a virtual storage. This one is not located at the consumers place, it is purely virtual. His rights of use are laid down in an agreement. Many scenarios are possible:

- The consumer rents or even buys a part of an external storage.
- The consumer rents or even buys a part of several external storages, having therefore a distributed storage.

Similar scenarios for the management of storages are offered to the producer of power packets. He can use parts of his storage for himself and make remaining volume available to other participants.

For an effective implementation, the orchestration of different sources must match the requirements to an energy packet. Therefore, in [17] the conception of a quantized capacity was introduced.

Consider a capacitor with capacity C as storage for electrical energy, which can be discharged over the internal resistance of the QFC (Fig. 23). The charge in a capacitor against time has an exponential decay, and so has the power: $P \sim e^{-t/RC}$. In Fig. 23 there are nine elementary energy packets available from the capacitor at the first-time interval.

As shown in [17], the quantization of power profiles follows a „power of 2“-structure. This means, the elementary energy packets can only be summarized in blocks of the power of 2:

$$\text{Number of elementary energy packets in one block} = dE \cdot 2^x,$$

where dE is an elementary energy packet, or the sum: $dE \cdot \sum g_x \cdot 2^x$, with weighting factor $g_x = \{0,1\}$.

For the first time interval in Fig. 23, we have $E = dE \cdot (1 \cdot 2^3 + 0 \cdot 2^2 + 0 \cdot 2^1 + 1 \cdot 2^0) = 9dE$.

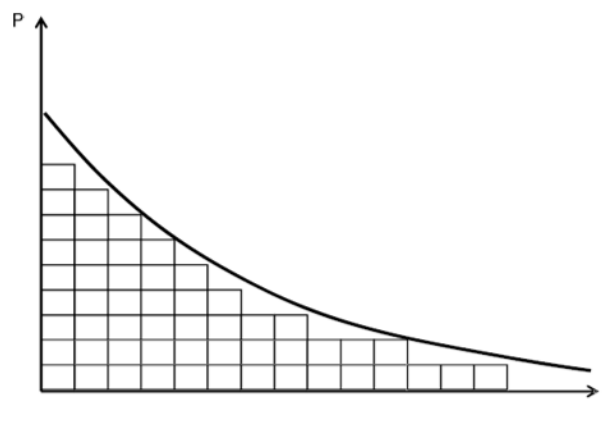

Fig. 23 Digitalized course of discharge of a capacitor.

Based on the quantized data about the capacitance of the capacitor, the energy management knows how much power the storage could offer. The energy management is responsible for the forecast of demand, the provision of power and the recharging of the capacitor after the power consumption.

How does the orchestration work? The control system creates the energy packets from the storage as required by the consumer. In every time interval the algorithm implemented in the control system takes the elementary energy packets from the sources to fulfill the requested profile [17]. Here we see quite clearly that the digitalization of the power is a prerequisite for the realization of the Quantum Grid.

As the costs of storage systems are continuously declining, they are becoming more and more economically attractive for private costumers.

9. Quantum Grid Gateway

The Quantum Grid Gateway is the first step to integrate the Quantum Grid into the existing grid, using new technical concepts for a cost-effective and systematic implementation as a parallel operation of the Quantum Grid into the grid we have nowadays. It was developed within a cooperation, the GIP and the group of Prof Monti at the E.ON research center of the technical university of Aachen, RWTH.

The traditional electrical grids provide power on demand. The customer has an agreement with his energy supplier and can then take (almost) as much energy as he wants at any time.

This is possible because of today's layout of the electrical grid: a small number of power stations generate electric power, which is then delivered along the distribution lines through the grid to the consumers as shown in Fig. 24.

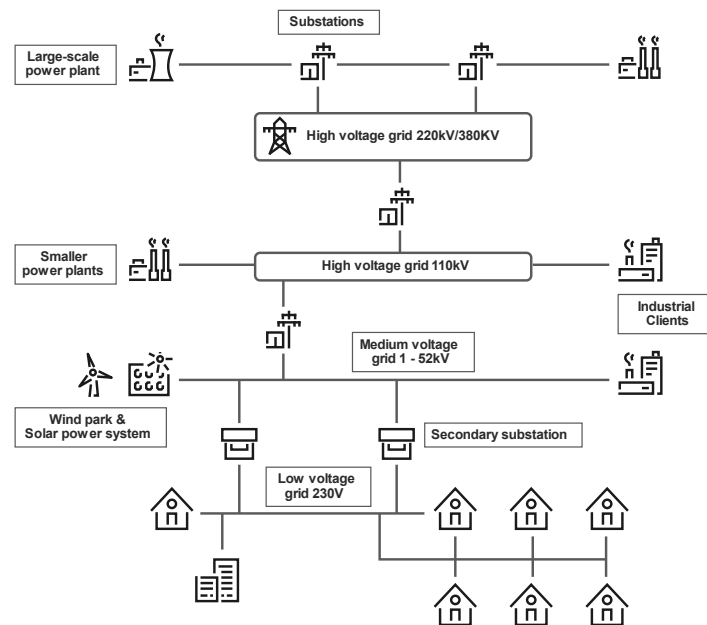

Fig. 24 Typical topology of the current electrical grid. The power flow is transformed from high voltage to medium voltage and finally down to low voltage at the customer side at transformer stations or substations.

In contrast, the Quantum Grid allows a dynamic distribution of energy by implying that the transmission of energy happens in form of energy packets, which are routed through the grid just as data packets through the internet. The routing takes place in the QGRs, which are the core elements of the Quantum Grid.

An immediate and complete conversion of the existing grid into a Quantum Grid is not expected. There will be a transition period with a hybrid solution. There are many options:

Initially, the Quantum Grid can be implemented in subnets or in individual voltage levels. The challenges inherent to this project will be the connection of the traditional grid with the Quantum Grid across the various voltage levels.

The low voltage level is particularly interesting for an implementation of the Quantum Grid, since many small regenerative producers feed power into the grid. Thus, a higher dynamic is expected at this level. To compensate the fluctuating power output, in the future, many substations have to be renewed and a massive network expansion has to take place. This costly endeavor would not be necessary in the case of a Quantum Grid.

There is also the possibility to integrate the Quantum Grid simultaneously at the medium voltage level. The substations are provided with a QGR with QFCs realized as Dual Active Bridges (DAB [14]), which we explained in the last section, with the following advantages:

- **Material saving:** the transformer in the DAB technology is much smaller, so a lot less copper is needed. This allows the upgrade of the substations with powerful electronics.

- **More Efficiency:** Thanks to modern power electronics and innovative topologies for power converters, the efficiency will become much higher as that of conventional transformers with Cu-coils.
- **Adjustable power** flows thanks to the flexible control of the converters and the power electronics.
- **Flexible gear ratio** compared to the fixed ratio in today's substations⁴.

Also, the digital transformation and the necessity of new mobility concepts as electro mobility is progressing rapidly [18]. The Quantum Grid is a flexible transmission grid, which meets these requirements. A multitude of renewable sources can be integrated without the need of balance energy or control energy. The connection between the different voltage levels is realized by bidirectional QGR which allows the power to flow in both directions.

The **Quantum Grid Gateway (QGG)** [19] has been investigated by Dr. Bernd Reifenhäuser (GIP) and Prof. Dr. Antonello Monti (E.ON ERC ACS, RWTH Aachen). It is a device to connect traditional grids and the Quantum Grid. In Fig. 25, the QGG represents the bridge between the medium voltage level (here: Quantum Grid) and the low voltage level (here: traditional grid).

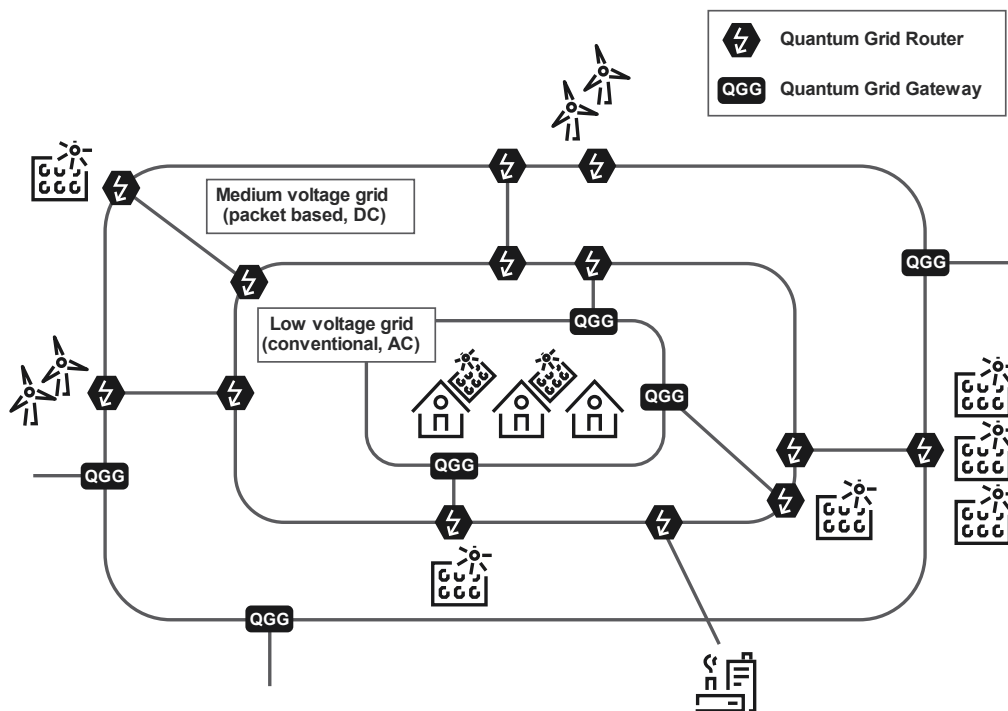

Fig. 25 The Quantum Grid Gateway (QGG) is the bridge between the traditional low voltage grid and the Quantum Grid at the medium voltage level. Both is possible: power flow control and voltage transformation.

The QGG is composed by a QGR in which the QFCs are realized as DABs, allowing both, power flow control and voltage transformation.

If the Quantum Grid were implemented in the medium voltage level, the substations would be upgraded by QGR thus becoming connecting nodes between the traditional and the Quantum Grid. Such a node has the following features:

1. **Routing and Control Plane**
 - a. Routing of data and energy packets,
 - b. Control of the Power Plane,
 - c. Communication between all the nodes as well as the sources and sinks on both grids.
2. **Power Plane**, with Power Router with Quantum Flow Controller and transmission lines. There the energy packets are transmitted physically.

⁴ There are many approaches to implement adjustable transformers (in German: RONT). For a few years, there are some investigation projects [FGE] based on traditional approaches, which do not allow power flow control.

Other options may be:

- a. The Quantum Grid and the traditional grid are on the same voltage level. In this case, the DAB just acts as a power flow controller.
- b. If there are two interconnected Quantum Grids with different voltage levels, the QGG does not act as a “gateway” but just transforms the voltage and sets the power flows as given by the data.

The grid is supposed to be divided into cells of high availability, connected by QGGs. They can interchange power at any time. If there happens to be a problem in one of the cells, this cell could be supplied by another cell, without affecting them. Each cell has its own routing and Routing and Control Plane with one or more routing and control instances, coherently coupled in order to avoid failures [20]. The planes are preferentially operated in Control Centers to offer Software defined functions to the Quantum Grid. This is a powerful method to prevent blackouts in the future, which is an important aspect regarding the economic consequences of such a blackout [21].

10. Ongoing research and outlook

The Quantum Grid represents a new, disruptive concept of power transmission. The energy is routed by intelligent algorithms implemented in the QGRs in form of packets through the grid.

Beyond this, further research has been done. For example, to build up an efficient Quantum Grid the orchestration of distributed sources and distributed energy storage devices are required. This can be achieved with the help of a so-called Quantum Power Cross Bar [17]. The Quantum Power Cross Bar manages the orchestration of different types of storages, regarding their capability in time, power and capacity. The storage devices may have different technologies, e.g. super caps, flywheels or lithium-ion batteries that are optimally combined when power must be provided. The quantization of electrical power as explained above allows the optimal management of storages.

Since 2017, we have further developed the technology and the method of the Quantum Cross Bar, so that with this method a packet-based overlay grid can be realized over a standard or smart grid. These results will be presented in a separate white paper to be published soon. We have a particular interest in Africa, which has a very poor infrastructure of electricity and communication. In 2017, 70% of the people in the Sub-Sahara States live on the countryside, and only about 10% of this rural population has access to electricity. And even for those who have access, there is a high failure rate. Energy needs are covered mostly by diesel generators, which are harmful to health and the environment.

Over the last few years, we have been working on this task and have developed the Quantum Grid out of the Box concept for this purpose. You can find more information about this in our white paper on our homepage.

One focus of our work was on how the Quantum Grid can be extended to handle volatile feed-in, demand variance and transmission losses. The Quantum Grid 4.0 answers these questions. As soon as the patent application of the Quantum Grid 4.0 is published (first in German), we will present it in a corresponding white paper.

The Quantum Grid, with the packet-based power transmission, is a revolutionary power supply system controlled by self-organized intelligent algorithms. We postulate that any solution, which is at the moment in the stage of development e.g. as the smart grid, will end up in a quantized grid with power flow control:

$$\lim_{t \rightarrow \infty} \text{Smart Grid} = \text{Quantum Grid}$$

Contact:

<https://www.gip.com/contact/>

11. Bibliography

- [1] B. Reifenhäuser and A. Ebbes, "Digitalisiertes Verteilungsnetz für die Stromversorgung," *EW dossier Smart Energy*, vol. 112, no. 9, pp. 40-42, 2013.
- [2] A. Ebbes and B. Reifenhäuser, "Method and apparatus for the directional transmission of electricity in an electricity grid". Patent United States: US9337655B2; European patent specification: EP2430723B1; Patent China: CN102439812B.
- [3] H. Saitoh and J. Toyoda, "A New Electric Power Network for Effective Transportation of Small Power of Dispersed Generation Plants," *Electrical Engineering in Japan*, vol. 117, no. 1, pp. 19-29, 1996.
- [4] R. Abé, "Multi-terminal power conversion device, multi-terminal power transfer device, and power network system". Patent United States: US 9013902B2.
- [5] R. Abé, H. Taoka and D. McQuilkin, "Digital Grid: Communicative Electrical Grids of the Future," *IEEE Transactions on Smart Grid*, vol. 2, no. 2, pp. 399-410, 2011.
- [6] "A note on two problems in connexion with graphs," in *Numerische Mathematik. 1*, 1959, S. 269–271.
- [7] R. Bellman, "On a routing problem," no. 16.
- [8] L. R. Ford Jr., "Network Flow Theory," 1956.
- [9] W. Nolting, *Grundkurs Theoretische Physik 4: Spezielle Relativitätstheorie*, 1999.
- [10] R. A. Serway and J. W. Jewett, *Principles of Physics: A Calculus-Based Text*.
- [11] B. Reifenhäuser and A. Sumper, "Power Blockchains - transparent und dezentral," *Magazin für die Energiewirtschaft. EW Spezial III*, pp. 34-36, 2016.
- [12] J.-M. Rodriguez-Bermunz, E. Prieto-Araujo, F. Girbau-Llistuella, A. Sumper, R. Villafafila-Robles and J.-A. Vidal-Clos, "Experimental validation of a single phase intelligent power router," *Sustainable Energy, Grids and Networks*, vol. 4, pp. 1-5, 2015.
- [13] R. De Doncker, D. Divan and M. Kheraluwala, "A three-phase soft-switched high power density DC/DC converter for high power applications," in *Conf. Rec. of the IEEE Industry Applications Society Annual Meeting*, Pittsburgh, 1988.
- [14] N. Soltau, H. Stagge and R. W. De Doncker, "Development and Demonstration of a Medium-Voltage High-Power DC-DC Converter for DC Distribution Systems," in *IEEE 5th Int. Symposium on Power Electronics for Distributed Generation Systems (PEDG)*, Galway (Ireland), 2014.
- [15] M. Kheraluwala, R. W. Gascoigne, D. M. Divan and E. D. Baumann, "Performance characterization of a high-power dual active bridge DC-to-DC converter," *IEEE Transactions on Industry Applications*, vol. 28, no. 6, 1992.
- [16] S. Inoue and H. Akagi, "A bidirectional DC-DC converter for an energy storage system with galvanic isolation," *IEEE Transactions on Power Electronics*, vol. 22, no. 6, 2007.
- [17] A. Ebbes and B. Reifenhäuser, "Electrical Power Distributor and Method for Power Distributing". Patent Germany: DRN 2014122216311900DE; Patent United States: US10361564B2, 22 12 2014.
- [18] B. Reifenhäuser, "Elektrifizierung 2.0 Strom – Der Treibstoff der Digitalisierung," *EW*, 12 2014.
- [19] A. Monti and B. Reifenhäuser, "Vorrichtung und Verfahren zum bidirektionalen Verbinden zweier Stromnetze". Patent Application WO002016207074A1, 2015.
- [20] B. Reifenhäuser and A. Ebbes, "Method and program for providing data coherence in networks". Patent Europe: EP2250588B1, 2008.
- [21] B. Reifenhäuser, "Blackoutprävention durch digitale Hochverfügbarkeitszellen," *EW*, 02 2014.

12. Inspirational resources:

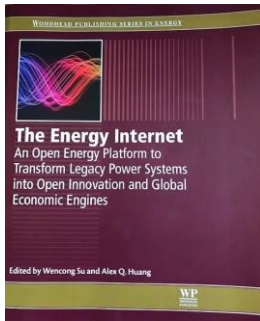

"The Energy Internet"

Ed. Wencong Su, Axel Q. Huang

ISBN (Online) 978-0-08-102215-3